

# TUĞRA



**BMC**

**CONSTRUCTION TRUCK  
TGR 3540 (6X4)**

### CABIN

Type	Low roof - Day Cab
Bunk	-
Cab suspension	Mechanical

### ENGINE

Brand / Model	Cummins ISL9E6C 400 (Euro 6 Step-C)
Type	Turbo Intercooler Diesel
Number of Cylinders	6
Displacement	8.9 l
Maximum Power	400 PS (298 kW) @ 2100 rpm
Maximum Torque	1700 Nm @ 1400 rpm
Diameter & Stroke	114 mm / 145 mm

### TANKS

Fuel Tank Capacity	300 l
Adblue Tank Capacity	74 l

### GEAR BOX

Brand / Model	ZF 16S1830 T0 (Manual)
Number of Gears	16 forward, 2 reverse
Gear ratio	13.80:1; 0.84:1 (Reverse: 12.92:1 / 10.80:1)
Clutch	400 mm, Double disk

### AXLES

Front Axle	
Load Capacity	9000 kg
Rear Axles	
Gear Ratio	5.4:1
Load Capacity	16000 kg + 16000 kg

### STEERING SYSTEM

Type	Hydraulic
------	-----------

### BRAKE SYSTEM

Brake System Type	Air operated dual circuit type drum brakes, ABS, ASR
-------------------	--

### Retarder Type

Engine Brake	Intarder (600 kW) [O] 252 kW [S]
--------------	-------------------------------------

### SUSPENSION

Front Axle	Parabolic springs, telescopic shock absorbers
Rear Axle	Parabolic springs, telescopic shock absorbers
Anti-roll Bar	1st and 3rd axles

### CHASSIS

Chassis Profile	Steel, 8mm+5mm
-----------------	----------------

### TYRES

Size / Number	315 / 80 R 22.5, 10+1
---------------	-----------------------

### RIMS

Size	9 x 22.5
------	----------

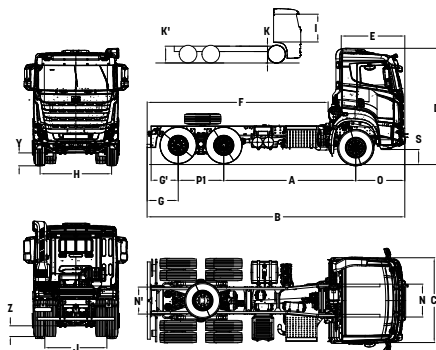

(1): K: 1189 K': 1094 (Loaded) [O]: Options  
(2): Y: 325 Z: 267 (Loaded) [S]: Standard

\*For Kerb weight calculation, minimum equipment, no driver, 20 liters of fuel, 5 liters of urea included.

Kerb weight may change depends on optional equipments.

### DIMENSIONS (mm)

A: Wheelbase	3900
B: Overall Length	7690
C: Overall Width	2550
D: Overall Height	3510
F: Useful Chassis Length	5350
I: Inner Height	1670 [Tunnel Height: 190]
O: Front Overhang	1500
G': Rear Overhang	940
H: Front Track	2120
J: Rear Track	1847
S: First Step Height	550
R: Inner Width	2155
K: Chassis Height	1170

### WEIGHTS (kg)

	Technical	Legal
Maximum weight loaded front axle	7000	7000
Maximum weight loaded rear axles	13400 + 13400	9500 + 9500
Gross vehicle weight	33800	26000

### Kerb Weights (kg)

1. Axle:	4999
2. Axle:	2385
3. Axle:	2316
Total:	9700*

### PERFORMANCE

Top speed (limited) (kph)	90
Turning radius (m)	8

### ELECTRICAL SYSTEM

Voltage	24 V
Batteries	2 x 12 V / 180 Ah
Alternator	120 A
Starter Motor	24 V

### STANDARD FEATURES

Air conditioner  
Radio/MP3/Bluetooth  
Cruise control  
Electrically operated and heated side mirrors  
Adjustable steering column  
Mechanically operated sunroof  
Anti-lock brake system (ABS)  
Immobilizer  
Single key with remote control and central locking  
Differential lock (for both axles)  
Digital tachograph  
Electrically operated windows  
Air suspended driver seat  
Adjustable driver seat armrest  
Seat headrest  
Seatbelt sensor (Driver)  
Driver and passenger sun visor  
Transmission PTO

### OPTIONAL FEATURES

Navigation  
7" Multimedia display  
ADR package  
Driver seat with air operated back support  
Adjustable passenger seat armrest  
Heated driver seat  
Fleet management system socket and module  
Intarder (600 kW)  
Electric Cab Lift  
Tire pressure monitoring system  
Engine PTO

All visuals, dimensions, characteristics and equipments are for information purposes only and they are not contractual. BMC reserves the right to modify them without prior warning. (October 2018)

### BMC OTOMOTİV SANAYİ VE TİCARET A.Ş.

HEADQUARTERS Oruç Reis Mah. Tem Otayolu Atış Alanı Mevkii Tekstilkent Caddesi No: 12 Koza Plaza A Blok 4.Kat 34235 Esenler / İSTANBUL / TÜRKİYE T. +(90 212) 438 04 30 F. +(90 212) 438 04 35

FACTORY Kemalpaşa Caddesi No: 288 Pınarbaşı 35060 Bornova / İZMİR / TÜRKİYE T. +(90 232) 477 18 00 F. +(90 232) 477 18 77 (78-79)

REGIONAL DIRECTORATE Beştepe Mahallesi Dumlupınar Bulvarı No: 34 A Blok (Armada İş Merkezi) 6/1 Kat: 20 Yenimahalle / ANKARA / TÜRKİYE T. +(90 312) 285 91 25-26-27 F. +(90 312) 285 91 28