

TUĞRA

TGR 3540 (6x4) TXT
CONSTRUCTION TRUCK



BMC

TURQUALITY®

CABIN

TYPE

Day Cab

CAB SUSPENSION

Mechanic

ENGINE

BRAND / MODEL

Cummins ISL9E6D (Euro 6)

TYPE

Turbo Intercooler Diesel

NUMBER OF CYLINDERS

6

DISPLACEMENT

8.9 L

MAXIMUM POWER

400 PS [298 kW] @ 2100 rpm

MAXIMUM TORQUE

1700 Nm @ 1400 rpm

DIAMETER & STROKE

114 mm / 145 mm

TANKS

FUEL TANK CAPACITY

300 L

ADBLUE TANK CAPACITY

74 L

GEAR BOX

BRAND / MODEL

ZF 12 TX 1815 T0 (Automatic) (S)

ZF 12 TX 1815 T0 (Automatic + Intarder) (O)

NUMBER OF GEAR

12 Forward, 2 Reverse

GEAR RATION

12,92:1 ; 0,77:1 (Reverse: 13;11 / 10,12:1)

CLUTCH

430 mm // (17") Single Disc

AXLES

FRONT AXLE

LOAD CAPACITY

900 kg

REAR AXLE

Gear Ration

5,41:1

LOAD CAPACITY

16000kg + 16000 kg

SUSPENSION

FRONT AXLE

100 mm Parabolic Leaf Springs,
Telescopic Shock Absorbers

REAR AXLE

Reverse Parabolic Tandem Springs

ANTI-ROLL BAR

Rear (3rd) and Front (1st) Axles

TYRES

SIZE / NUMBER

315 / 80 R 22.5, 10+1 (O)

13 R22.5, 10+1 (S)

RIMS

SIZE

9 X 22.5

PERFORMANCE

TOP SPEED (LIMITED) (km/h)

90

TURNING RADIUS (m)

8.0

ELECTRICAL SYSTEM

VOLTAGE

24 V

BATTERIES

2 x 12 V / 180 Ah

ALTERNATOR

120 A

STARTER MOTOR

24 V

STEERING SYSTEM

TYPE

Hydraulic

BRAKE SYSTEM

BRAKE SYSTEM TYPE

Air Operated Dual Circuit Type
Ø410x200 Z-Cam Drum Brakes, ABS, ASR

RETARDER TYPE

Intarder (600 kW) (O)

ENGINE BRAKE

252 kW (S)

CHASSIS

CHASSIS PROFILE

Steel, 8mm+5mm (Reinforced)

STANDARD ACCESSORIES

Manually Operated Digital Air Conditioner (6 kW)

Radio/MP3/Bluetooth

2 USB + Cigarette Lighter (Driver Side)

2 USB + 12V (Passenger Side), 1 USB (Multimedia)

4 Points Independent Mechanic Cab Suspension

Cruise Control

Electrically Operated and Heated Side Mirrors

Adjustable Steering Column

Manually Operated Sunroof

Antilock Braking System (ABS)

Anti Slip Regulation (ASR)

Immobilizer

Single Key with Remote Control and Central Locking

Differential Lock

Digital Tachograph

Electrically Operated Windows

Air Suspended Driver Seat

Adjustable Driver Seat Armrest

Seat Headrest

Seatbelt Sensor (Driver)

Driver and Passenger Sun Visor

Spare Wheel

Front Fog Lamps

Electrically Operated Headlight Leveling

Front Dust Protection

Engine PTO - REPTO

Lamp Under Hood

Lamp Under Cab

Tyre Inflation Valve

Front Light Protection

Body Structure Module

OPTIONAL ACCESSORIES

7" Multimedia Display

Driver Seat with Air Operated Back Support

Heated Driver Seat

Adjustable Passenger Seat Armrest

Fleet Management System Socket and Module

Intarder (600 kW)

Electric Cab Lift

Tire Pressure Monitoring System

Single Type Clutch System

Transmission PTO

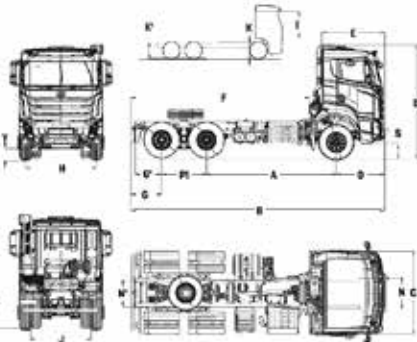

DIMENSIONS (mm)

A: Wheelbase	3900	H: Front Track	2120
B: Overall Length	8255	J: Rear Track	1847
C: Overall Width (Excluding Mirrors)	2550	S: First Step Height	315/80/R22,5: 518 13/R22,5: 540
D: Overall Height	315/80/R 22,5: 3480 13R/22,5: 3502	R: Inner Width	2155
F: Useful Chassis Length	5645	K': Chassis Height	315/80/R22,5: 1173 13/R22,5: 1121
I: Inner Height	1670	PI: 2. and 3. Axle Distance	1350
O: Front Overhang	1505		
G: Rear Overhang	1205		

WEIGHTS (kg)

	TECHNICAL	LEGAL	KERB WEIGHTS (kg)
MAXIMUM WEIGHT LOADED FRONT AXLE	8000	7000	1. AXLE 4950
MAXIMUM WEIGHT LOADED REAR AXLE	13400+13400	9500+9500	2. AXLE 2390
GROSS VEHICLE WEIGHT	34800	26000	3. AXLE 2280
			TOTAL 9620*

*For Kerb weight calculation, minimum equipment, no driver, 20 liters of fuel, 5 liters of urea included. Kerb weight may change depends on optional equipments.

Y:325 Z:267 (Loaded)

[O] Options [S] Standard

BMC reserves the right to change the technical specifications of the products without prior notice (April 2024)

BMC OTOMOTİV SANAYİ VE TİCARET A.Ş.



Kemalpaşa Caddesi No:288 Pınarbaşı 35060 Bornova / İZMİR TÜRKİYE



444 9 262



www.bmc.com.tr