

TUGRA



BMC

ROAD TRUCK
TGR 3232 (8X2) SLEEPER CABIN

CABIN

Type	Standard roof - Sleeper Cab
Bunk	1
Cab suspension	Air

ENGINE

Brand / Model	Cummins ISB6.7E6C 320 (Euro 6 Step-C)
Type	Turbo Intercooler Diesel
Number of Cylinders	6
Displacement	6.7 l
Maximum Power	320 PS (239 kW) @ 2300 rpm
Maximum Torque	1200 Nm @ 1100 rpm
Diameter & Stroke	107 mm / 124 mm

TANKS

Fuel Tank Capacity	500 l
Adblue Tank Capacity	74 l

GEAR BOX

Brand / Model	ZF 9 S 1310 TD, Manual
Number of Gears	9 forward, 1 reverse
Gear ratio	12.73:1 ; 1.00:1 (Reverse: 12.04:1)
Clutch	430 mm, Single disk

AXLES

Front Axle

Load Capacity	7000 kg
---------------	---------

Rear Axle

Diff. Number of Speeds	Single speed
Gear Ratio	4.33:1
Load Capacity	13000 kg

Self Steer Lift Axle

Load Capacity	7100 kg
---------------	---------

Tag Axle

Load Capacity	9000 kg
---------------	---------

STEERING SYSTEM

Type	Hydraulic
------	-----------

BRAKE SYSTEM

Brake System Type	Air operated dual circuit type disc brakes, ABS, ASR
Retarder Type	Electromagnetic (575 kW) [O]

SUSPENSION

Front Axle	Semi-elliptical springs, telescopic shock absorbers
Rear Axle	Semi-elliptical springs, telescopic shock absorbers
Anti-roll Bar	Rear (3rd) and front (1st) axles

CHASSIS

Chassis Profile	Steel, 8mm+5mm
-----------------	----------------

TYRES

Size / Number	315 / 80 R 22.5, 12+1
---------------	-----------------------

RIMS

Size	9 x 22.5
------	----------

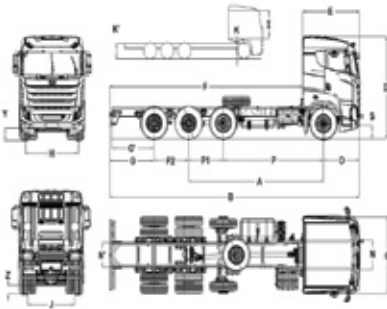

(1) Y: 275 Z: 243 (Loaded) [O]: Options [S]: Standard

*For Kerb weight calculation, minimum equipment, no driver, 20 liters of fuel, 5 liters of urea included.

Kerb weight may change depends on optional equipments.

DIMENSIONS (mm)

A: Wheelbase	5300
B: Overall Length	9850
C: Overall Width	2545
D: Overall Height	3415 (3950 sp)
F: Useful Chassis Length	7420
I: Inner Height	1770 [Tunnel Height: 190]
O: Front Overhang	1440
G: Rear Overhang	1760
H: Front Track	2083
J: Rear Track	1838
S: First Step Height	513
R: Inner Width	2155
K: Chassis Height	1112

WEIGHTS (kg)

	Technical	Legal
Maximum weight loaded front axle	7000	7000
Maximum weight loaded rear axles	7000 + 13000 + 9000	7000 + 10500 + 7500
Gross vehicle weight	35600	32000

Kerb Weights (kg)

1. Axle:	5052
2. Axle:	875
3. Axle:	2000
4. Axle:	1628
Total:	9555*

PERFORMANCE

Top speed (limited) (kph)	90
Turning radius (m)	9.9

ELECTRICAL SYSTEM

Voltage	24 V
Batteries	2 x 12 V / 180 Ah
Alternator	120 A
Starter Motor	24 V

STANDARD FEATURES

Air conditioner
Radio/MP3/Bluetooth
Cruise control
Electrically operated and heated side mirrors
Adjustable steering column
Electrically operated sunroof
Anti-lock brake system (ABS)
Immobilizer
Single key with remote control and central locking
Differential lock
Digital tachograph
Self steer axle lifting (Automatically)
Electrically operated windows
Air suspended driver seat
Adjustable driver seat armrest
Seat headrest
Seatbelt sensor (Driver)
Driver and passenger sun visor
Dry type cab heater
Tag axle lifting system

OPTIONAL FEATURES

Navigation	Tire pressure monitoring system
7" Multimedia	Aluminum rim
ADR package	Electric Cab Lift
Axle load indicator	Transmission PTO
Retarder	Pad wear indicator
Refrigerator (55 lt)	
Driver seat with air operated back support	
Adjustable passenger seat armrest	
Heated driver seat	
Roof spoiler	
Fleet management system socket and module	

All visuals, dimensions, characteristics and equipments are for information purposes only and they are not contractual. BMC reserves the right to modify them without prior warning. (October 2018)

BMC OTOMOTİV SANAYİ VE TİCARET A.Ş.

HEADQUARTERS Oruç Reis Mah. Tem Otayolu Atış Alanı Mevkii Tekstilkent Caddesi No: 12 Koza Plaza A Blok 4.Kat 34235 Esenler / İSTANBUL / TÜRKİYE T. +(90 212) 438 04 30 F. +(90 212) 438 04 35

FACTORY Kemalpaşa Caddesi No: 288 Pınarbaşı 35060 Bornova / İZMİR / TÜRKİYE T. +(90 232) 477 18 00 F. +(90 232) 477 18 77 (78-79)

REGIONAL DIRECTORATE Beştepe Mahallesi Dumlupınar Bulvarı No: 34 A Blok (Armada İş Merkezi) 6/1 Kat: 20 Yenimahalle / ANKARA / TÜRKİYE T. +(90 312) 285 91 25-26-27 F. +(90 312) 285 91 28